

DESIGN NOTES

High Frequency Active Antialiasing Filters – Design Note 313

Philip Karantzalis

Introduction

High frequency (1MHz or higher) active lowpass filters are now practical alternatives to passive LC filters mainly due to the availability of very high bandwidth (100MHz or higher) integrated amplifiers. Analog signal filtering applications with bandwidths in the megahertz region can be implemented by a discrete active filter circuit using resistors, capacitors and a 400MHz operational amplifier such as the LT[®]1819 or the LT6600-10, a fully integrated lowpass filter. The LT6600-10 has a fixed 10MHz frequency response equivalent to a fourth order flat passband Chebyshev function. An LT1819-based active RC lowpass filter can be designed to have a Chebyshev, Butterworth, Bessel or custom frequency response (up to 20MHz).

The LT6600-10 Lowpass Filter

The LT6600-10 is a fully integrated, differential, fourth order lowpass filter in a surface mount SO-8 package (Figure 1). Two external resistors ranging from 1600Ω to 100Ω set the differential gain in the filter's passband from -12dB to 12dB respectively. The LT6600-10 passband gain ripple is a maximum of 0.7dB to -0.3dB up to 10MHz and attenuation is typically 28dB at 30MHz and 44dB at 50MHz. The signal to noise ratio (SNR) at the filter's output is 82dB with a 2V_{P-P} signal for a passband gain equal to one (a SNR suitable for up to 14 bits of resolution). In addition to lowpass filtering, the LT6600-10 can

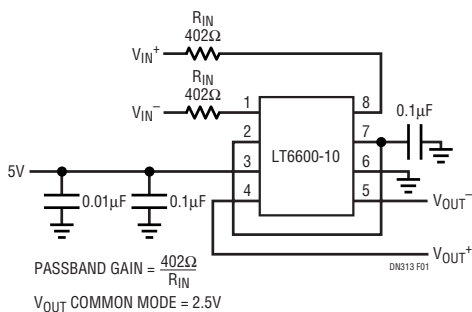

Figure 1. LT6600-10 10MHz, Lowpass Filter Features a Single Supply and Only Two External Resistors

level shift the input common mode signal. For example, with a single 3V supply, if the input common mode voltage is 0.25V, then the output common mode voltage can be set to 1.5V. The LT6600-10 operates with single 3V or 5V or dual 5V power supplies.

An LT1819-Based RC Lowpass Filter

The LT6600-10 greatly simplifies lowpass filter design because it only requires two external resistors to set the differential gain, but the passband is fixed. For more flexibility, the LT1819 400MHz, high slew rate, low noise and low distortion dual operational amplifier is a good choice. Figure 2 shows a differential, 10MHz, 4th order, lowpass filter using two LT1819s. This approach allows for adjustable passband up to 20MHz but at the expense of a large number of passive and active components and high sensitivity to the variation of component values. For example, a component sensitivity analysis of Figure 2 shows that in order to maintain a passband ripple similar to the LT6600-10 (± 0.5 dB up to 10MHz), the component tolerance must not exceed $\pm 0.5\%$ for the resistors and 1% for the capacitors. Also, the LT1819 gain-bandwidth product should not be less than 300MHz. If a Butterworth, Bessel or custom filter response is desired, $\pm 1\%$ resistors and $\pm 5\%$ capacitors are adequate. These filters have lower sensitivity than a "flat" passband Chebyshev filter. The LT1819-based filter operates with single 5V or dual 5V power supplies (for a single 3V power supply filter circuit use an LT1807, a dual 325MHz, rail-to-rail operational amplifier).

Antialiasing 10MHz Filters for a Differential 50Mps ADC

An LT6600-10 or an LT1819-based 10MHz lowpass filter provides adequate stopband attenuation for reducing aliasing signals at the input of a high speed analog-to-digital converter (ADC) such as the LT1744, a 50Mps, differential input ADC. Figure 3 shows the gain response

LTC and LT are registered trademarks of Linear Technology Corporation.

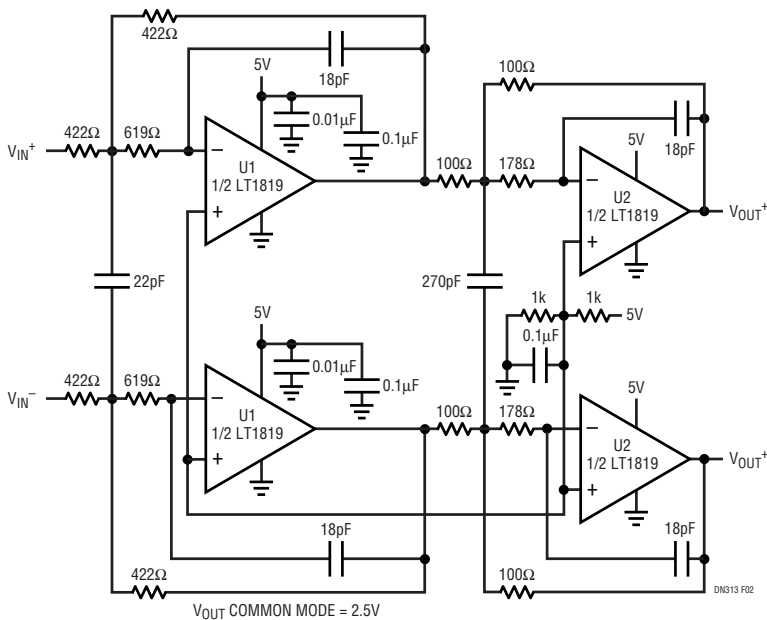

Figure 2. Another 10MHz, Single Supply Lowpass Filter, Similar to Figure 1. This Circuit Features the LT1819 Op Amp and Adjustable Bandwidth Up to 20MHz

of the LT6600-10 and the LT1819-based 10MHz filters. The LT1819 filter is designed to have higher attenuation at 20MHz than the LT6600-10 filter in order to achieve sufficient stopband attenuation. The stopband attenuation beyond 40MHz of the LT1819 circuit is limited to -42dB by printed circuit stray paths and differential component mismatches that decrease the common mode rejection at very high frequencies. The stopband attenuation of the fully integrated LT6600-10 filter continues increasing beyond 40MHz. Figure 4 shows the DC to 10MHz plot of a 1MHz 2V_{p-p} differential sine wave processed by an LT6600-10 plus an LT1744 14-bit ADC. The plots are an averaged 4096-point FFT of a 1MHz sine wave digitized at 50 million samples per second. The 1MHz harmonic distortion of Figure 4 is virtually the same when an LT1819-based filter is used with an LT1744. In a 10MHz bandwidth, the measured signal-to-noise plus distortion for the LT6600-10 plus LT1744 circuit is 74.5dB and essentially equal to the dynamic range of an LT1744 ADC (a minimum of 75.5dB for a 2V_{p-p} signal). The LT1819-based filter is slightly noisier, the measured signal-to-noise ratio plus distortion for the LT1819 plus LT1744 circuit is 71.5dB.

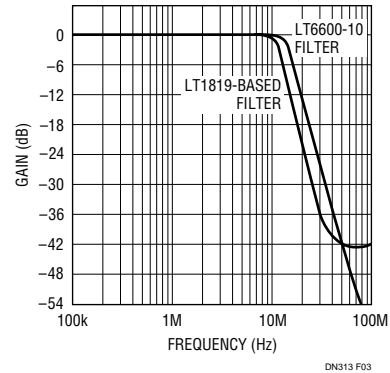

Figure 3. The Frequency Response of the Two 10MHz Antialiasing Filters Shown in Figures 1 and 2

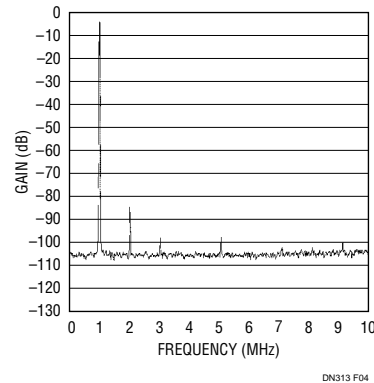

Figure 4. Spectral Plot of a 1MHz, 2V_{p-p}, Differential Sine Wave Input to an LT6600-10 Filter Plus an LT1744 14-Bit ADC (a DC to 10MHz Plot of a 4096-Point Averaged FFT with a 50MHz Sample Rate)

Conclusion

The LT6600-10 offers a high performance, 10MHz differential filter with gain, in a small package (SO-8) while the LT1819 op amp can be used to create a variety of differential filters up to 20MHz.

Data Sheet Download

<http://www.linear.com/go/dnLT6600-10>
<http://www.linear.com/go/dnLT1819>

For literature on our Lowpass Filters, call **1-800-4-LINEAR**. For applications help, call (408) 432-1900, Ext. 2156